

CEILING MOUNT CM50-LCD

A Rugged Ceiling Support System for Compact BARCO Projectors

The Ceiling Mount CM50-LCD with pulley system enables mounting any 2000 or 3000 Series BARCO projector, to virtually any ceiling structure. The concept makes it possible to adapt the projector perfectly for normal mounting requirements in a safe and reliable manner. The ceiling mount CM50-LCD is specifically developed for rooms with a lowered ceiling, but can be used in other rooms as well by omitting the upper plate and the three threaded rods. A simple and effective mechanical locking system ensures the projector is securely positioned. After installation, the pulley system can be removed. Removing the projector from its mount is easily achieved by squeezing the arms of the locking system.

Features

- The Ceiling Mount can be used in two ways:
 1. For direct mount of the projector to the ceiling, without use of the pulley system or
 2. For lowered mounting. The mounting height is then adjustable between 7,6 cm to 101,6 cm to the ceiling when using the support, pulley system and rods
- The locking system prevents torsion or swing of the projector
- Four corner screws makes it possible to level the projector around the horizontal axis and perpendicular to the screen
- Three threaded rods allows leveling of the projector in the projector plane and perpendicular to the screen
- The holder system provides easy mounting of the projector
- Easy unlocking by squeezing the arms of the lock holder system
- The pulley system can be removed after installation



Technical Specifications

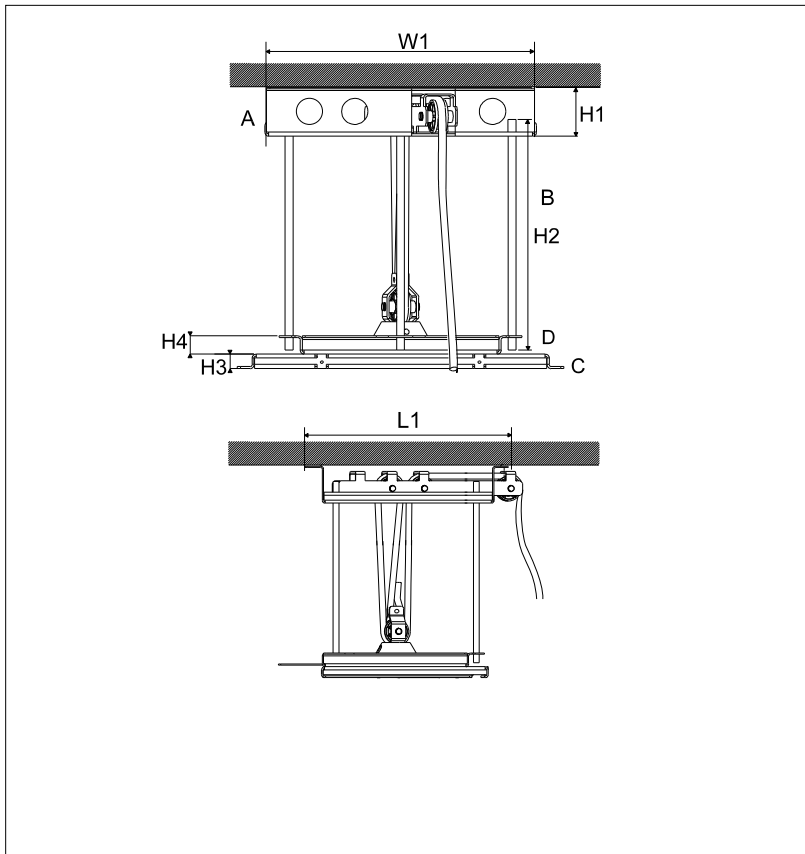

Dimensions	inch	mm
Upper support (A):		
L1	16.8	426
W1	16.0	408
H1	2.9	75
Threaded rods (B):		
H2	39.4	1000
(length adaptable)		
Projector support (C):		
H3	0.9	22
Center plate (D):		
H4	1.1	28

Color
Black

Weight
Net weight: 33 lbs. / 14.9 kg
Maximum load: 110 lbs. / 49.8 kg

The ceiling should be capable of supporting a weight of at least 551 lbs. / 250 kg

Order Information
2000/3000 Series LCD Projectors⁽¹⁾
CM 50 with pulley R9829610
CM 50 without pulley R9829611

(1) Includes the Ceiling Mount Adaptor Plate.



BARCO Projection Systems is an ISO 9001 registered company.

The information and data given are typical for the equipment described. However any individual item is subject to change without any notice.

