

# CEILING MOUNT CM50-CRT

## A Rugged Ceiling Support System for Compact BARCO Projectors

The ceiling mount CM50-CRT with pulley system enables mounting any 700 Series BARCO projector, to virtually any ceiling structure.

The concept makes it possible to adapt the projector perfectly for normal mounting requirements in a safe and reliable manner.

The ceiling mount CM50-CRT is specifically developed for rooms with a lowered ceiling, but can be used in other rooms as well by omitting the upper plate and the three threaded rods. A simple and effective mechanical locking system ensures the projector is securely positioned. After installation, the pulley system can be removed. Removing the projector from its mount is easily achieved by squeezing the arms of the locking system.

### Features

- The ceiling mount can be used in two ways:
  1. For direct mount of the projector to the ceiling, without use of the pulley system or
  2. For lowered mounting. The mounting height is then adjustable between 7,6 cm to 101,6 cm to the ceiling when using the support, pulley system and rods
- The locking system prevents torsion or swing of the projector
- Four corner screws makes it possible to level the projector around the horizontal axis and perpendicular to the screen
- Three threaded rods allows leveling of the projector in the projector plane and perpendicular to the screen
- The holder system provides easy mounting of the projector
- Easy unlocking by squeezing the arms of the lock holder system
- The pulley system can be removed after installation



# Technical Specifications

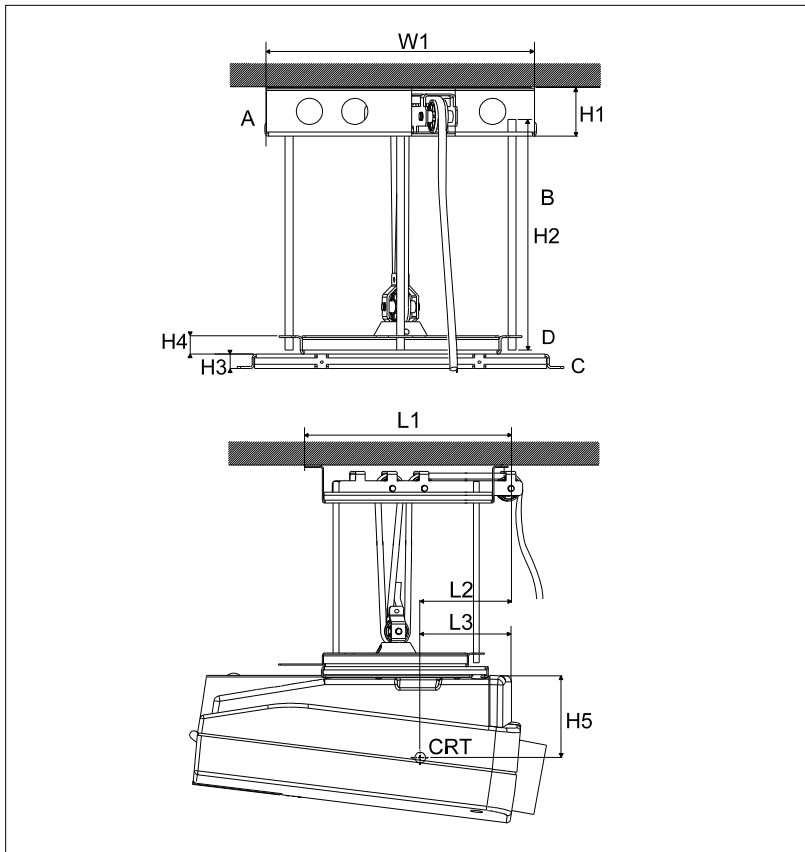

Dimensions	inch	mm
Upper support (A):		
L1	16.8	426
W1	16.0	408
H1	2.9	75
Threaded rods (B):		
H2	39.4	1000
(length adaptable)		
Projector support (C):		
H3	0.9	22
L3	7.3	186
Center plate (D):		
H4	1.1	28
L2	7.2	184
H5	6.5	165

Color  
Black

Weight  
Net weight: 33 lbs. / 14.9 kg  
Maximum load: 110 lbs. / 49.8 kg

The ceiling should be capable of supporting a weight of at least 551 lbs. / 250 kg

Order Information  
700 Series CRT projectors  
CM 50 with pulley R9827990  
CM 50 without pulley R9827991



BARCO Projection Systems is an ISO 9001 registered company.

The information and data given are typical for the equipment described. However any individual item is subject to change without any notice.



BARCO Projection System - Head Office  
Noordlaan 5, 8520 Kuurne, Belgium  
Tel: +32/56/368 211 Fax: +32/56/351 651  
E-mail: sales.bps@barco.com  
Visit BARCO at the web: www.barco.com

